

auto electrical parts

Technical Information Sheet

Part No. 0-097-89

Commercial 12/24 volt LED stop and tail lamp with stud fixing. Black plastic body. I 140 x w 82 x h 140mm. ECE approved.

Additional information

Red wire Stop
Brown wire Tail
White wire Ground/negative

A black bezel, part 0-097-98, is available to replace the base and allow a shallower fitting.



Technical Drawing (not to scale)

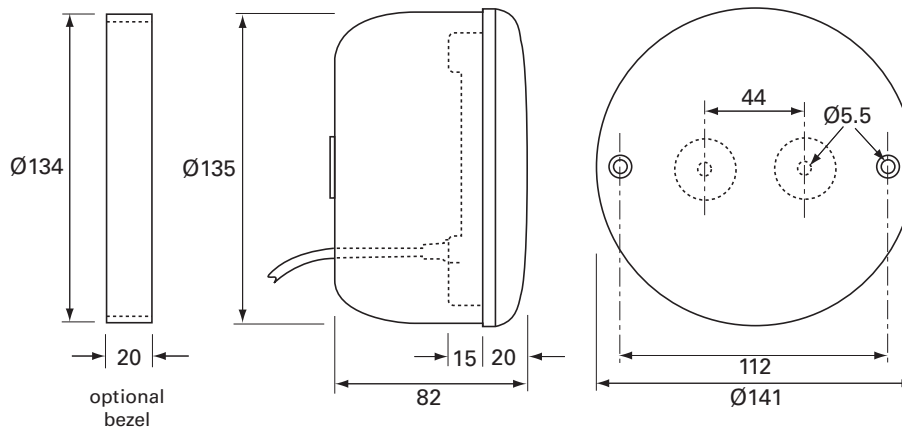

Specification

Type	Commercial rear lamp
Light source	45 LEDs
Voltage	10 - 30 volt dc
Current at 12/24v	Stop 0.25/0.13 amp Tail 0.03/0.02 amp
Lens	Acrylic
Body material	Housing ABS, base polycarbonate
Lead	400mm
Operating temp	-25°C to +60°C
Weight	360g
Dimensions	See diagram above
Protection	IP65
Compliance	ECE

The information contained in this document is correct to the best of our knowledge at the time of printing. However, specifications may change at any time without notice.